



ASIONIC 400-4

MULTIPATH ULTRASONIC FLOW METER

ASIONIC 400-4

MULTIPATH ULTRASONIC FLOW METER

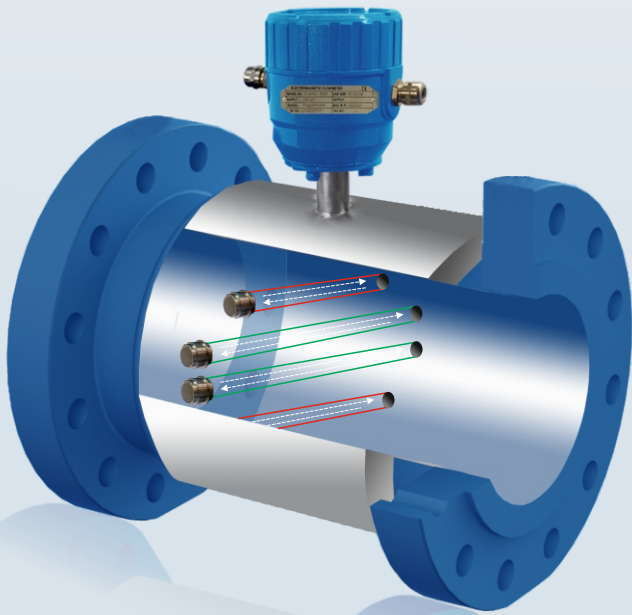

Features

- FULL BORE ULTRASONIC FLOW METER FOR LIQUID MEASUREMENT
- TRANSIT TIME SENSING TECHNOLOGY
- FOUR PATH CHORDAL DESIGN FOR OPTIMAL LINEARITY AND REPEATABILITY
- EMPTY PIPE INDICATION AND PARTIAL FLOW MEASUREMENT
- HIGH ACCURACY +/- 0.2% OF MEASURED VALUE
- NEGLIGIBLE PRESSURE DROP
- OPTIONAL PRESSURE & TEMPERATURE MEASUREMENT
- IoT ENABLED DEVICE
- WET CALIBRATION AT ISO17025-2017 NABL (ILAC) ACCREDITED CALIBRATION LABORATORY
- SUITABLE FOR CLEAN CONDUCTIVE / NON CONDUCTIVE LIQUIDS

ASIONIC 400-4

MULTIPATH ULTRASONIC FLOW METER

Electronet series ASIONIC[®]-400-4 Ultrasonic flow meters give the flexibility to install a reliable flow meter, virtually anywhere, without distorting accuracy and performance. The flow meter is extremely easy to use, simple to install and requires no regular maintenance. The product is engineered for various industrial as well as domestic applications such as Municipal and Industrial Water

applications, Cooling tower, Water treatment, etc. The LCD display provides indication for flow rate and totalized flow with key selection. The display auto shuts off after 10 minutes, which increases the battery life in case of battery powered flow meter. The display can be turned ON by pressing the 'enter' key.

Technical Specifications

Media	Liquids
Line Size	50 NB to 600 NB
Electronics	1) Integral (Local) 2) Remote
Output	4 to 20mA DC, Pulse (Open Collector), Pulse (Active TTL), Frequency (0 to 1 KHz)
Communication Output	RS485 (MODBUS RTU), GSM, GPRS & RF
Viscosity	200 cp maximum
Display	LCD Display - 6 digit for Flow Rate & 8 digit for Totalised Flow
Calibration Range	As per requirement (Factory Calibrated)
Accuracy	< ± 0.2% of M.V. ± 3mm /sec for Velocity Range 0.3 m/s to 6 or 12 m/s
Linearity	± 0.2% of M.V.
Repeatability	± 0.1% of M.V.
Temperature Coefficient	± 0.05% per °C
Process Temperature	-20°C to 85°C maximum
Process Pressure	16 kg/cm ² maximum Higher on Request
Material of Construction	Flow tube - SS304, SS316
Power Supply	24V DC (+/-10%) / Solar Powered / Battery Powered
Low Battery indication	Provided
Battery Life	5 to 10 Years depending on sampling time
Response Time	Less than 10 Sec.
Electronic Protection Class	Field Mount Weather Proof IP-67, DIN Standard (IP 54), Flameproof (CMRI IIA IIB Certified)
Flow Tube	IP-68
Process Connections	ASA 150 Flanged (As per table B 16.5) Other on requirement
Ambient Conditions	Temperature -20 to 70°C / Humidity 5 to 95% Non Condensing
Data Logging	For 10 Years (Per day 1 Sample)
Certification	

TABLE : Dimensional Details Of Flange, as Per ASA 150 # B-16.5 Refer Drg. Fig.1 & 2

Line Size		Flange Diameter D (mm)	Diameter of Raised Face R (mm)	Diameter of Bolt Hole Circle DBC (mm)	Diameter of Bolt Hole (mm)	No. of Holes	Thickness of Flange	Flange Distance 'FD'	Flow Range (m ³ /hr) for Velocity 0.3m/s to 6m/s	
Inch	NB								Fixed Inline	Min.
2"	50	152.4	92.1	120.6	19.0	4	19.0	300	2.12	42.4115
2½"	65	177.8	104.8	139.7	19.0	4	22.2	350	3.58	71.675
3"	80	190.5	127.0	152.4	19.0	4	23.8	350	5.42	108.573
4"	100	228.5	157.2	190.5	19.0	8	23.8	360	8.48	169.646
5"	125	254.0	185.7	215.9	22.2	8	23.8	400	13.25	265.071
6"	150	279.4	215.9	241.3	22.2	8	25.4	420	19.085	381.703
8"	200	342.9	269.9	298.4	22.2	8	28.6	470	33.929	678.584
10"	250	406.4	323.8	361.9	25.4	12	30.2	550	53.014	1060.28
12"	300	482.6	381.0	431.8	25.4	12	31.8	620	76.340	1526.81
14"	350	533.4	412.7	476.2	28.6	12	34.9	680	103.908	2078.16
16"	400	596.9	469.9	539.7	28.6	16	36.5	750	135.716	2714.33
18"	450	635.0	533.4	577.8	31.7	16	39.7	800	171.766	3435.33
20"	500	698.5	584.2	635.0	31.7	20	42.9	870	212.057	4241.15
24"	600	812.8	692.1	749.3	34.9	20	47.6	1000	305.362	6107.25

Note : Flange to flange distance (FD) Tolerance : 1) 2"(50NB) to 6"(150NB) : +/-3mm 2) 8"(200NB) to 24"(600NB) : +/-5mm

- All dimensions are in 'mm'
- For dimensions of line size above 600NB, please consult factory.
- Typical mounting dimensions are for reference only.
- Wet Calibrated at IEC/ISO/EN17025 Accredited Calibration Laboratory.
- Flow meter should be selected with the help of Nomograph (recommended full scale velocity).
- Flow indication of 6 digit max. up to 999999.
- Recommended for Dual Path (2" to 3") , Three Path (4" to 6") & Four Path (8" to 24")

Assembly Overview - Electronics

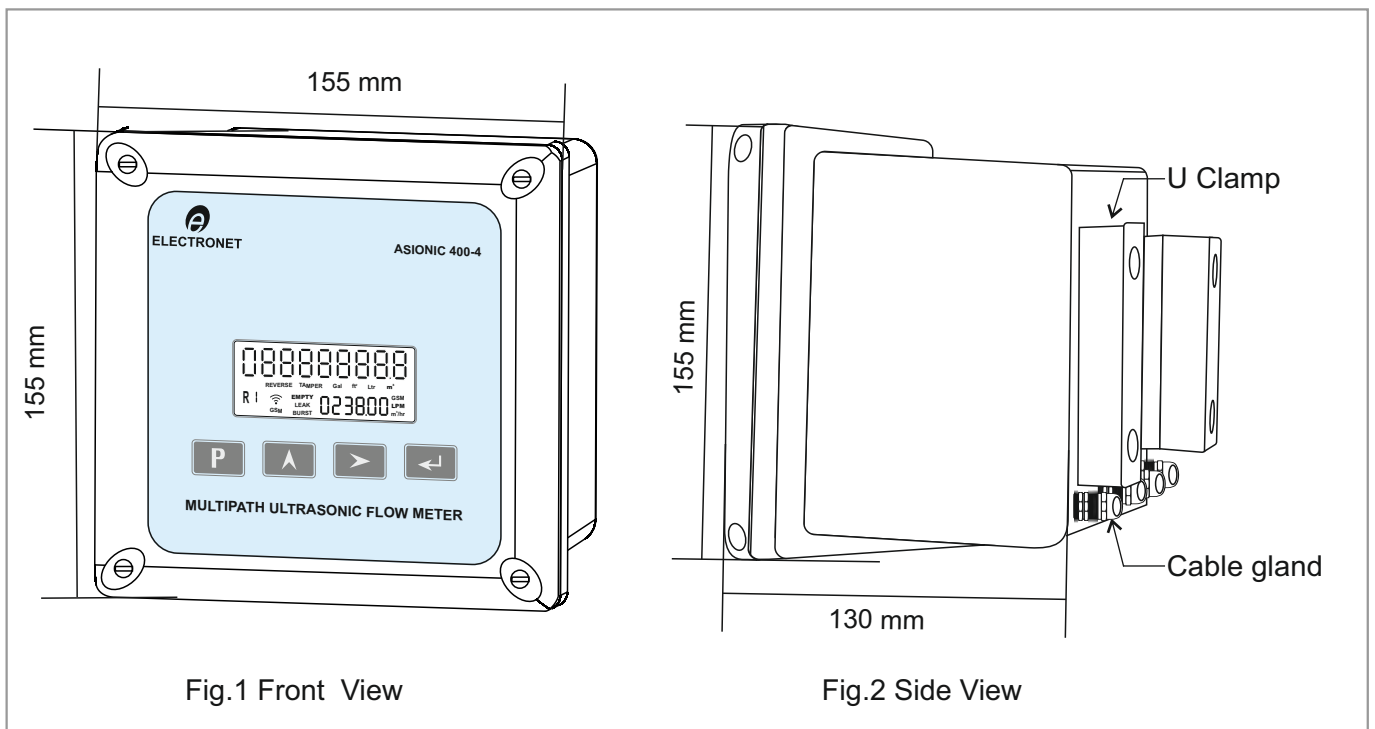
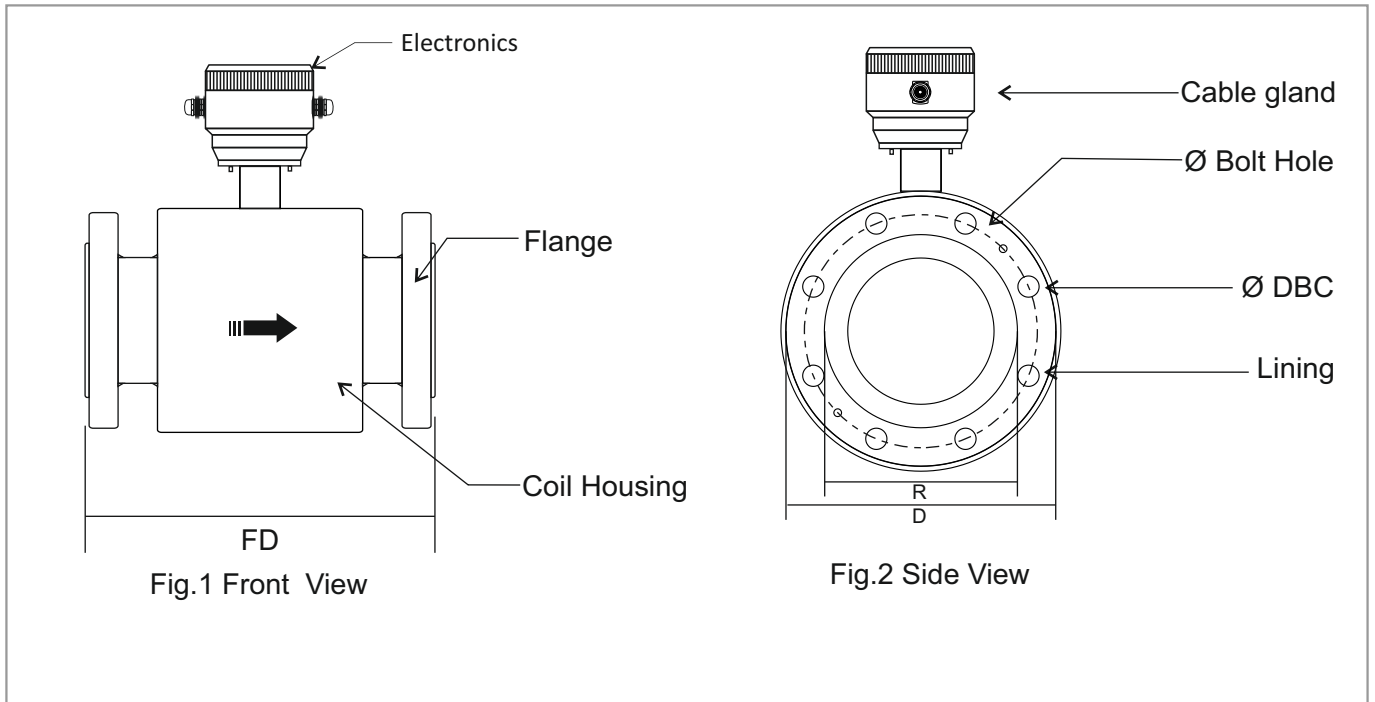

Fig.1 Front View

Fig.2 Side View

Assembly Overview - Flow Tube



General Arrangement Drawing

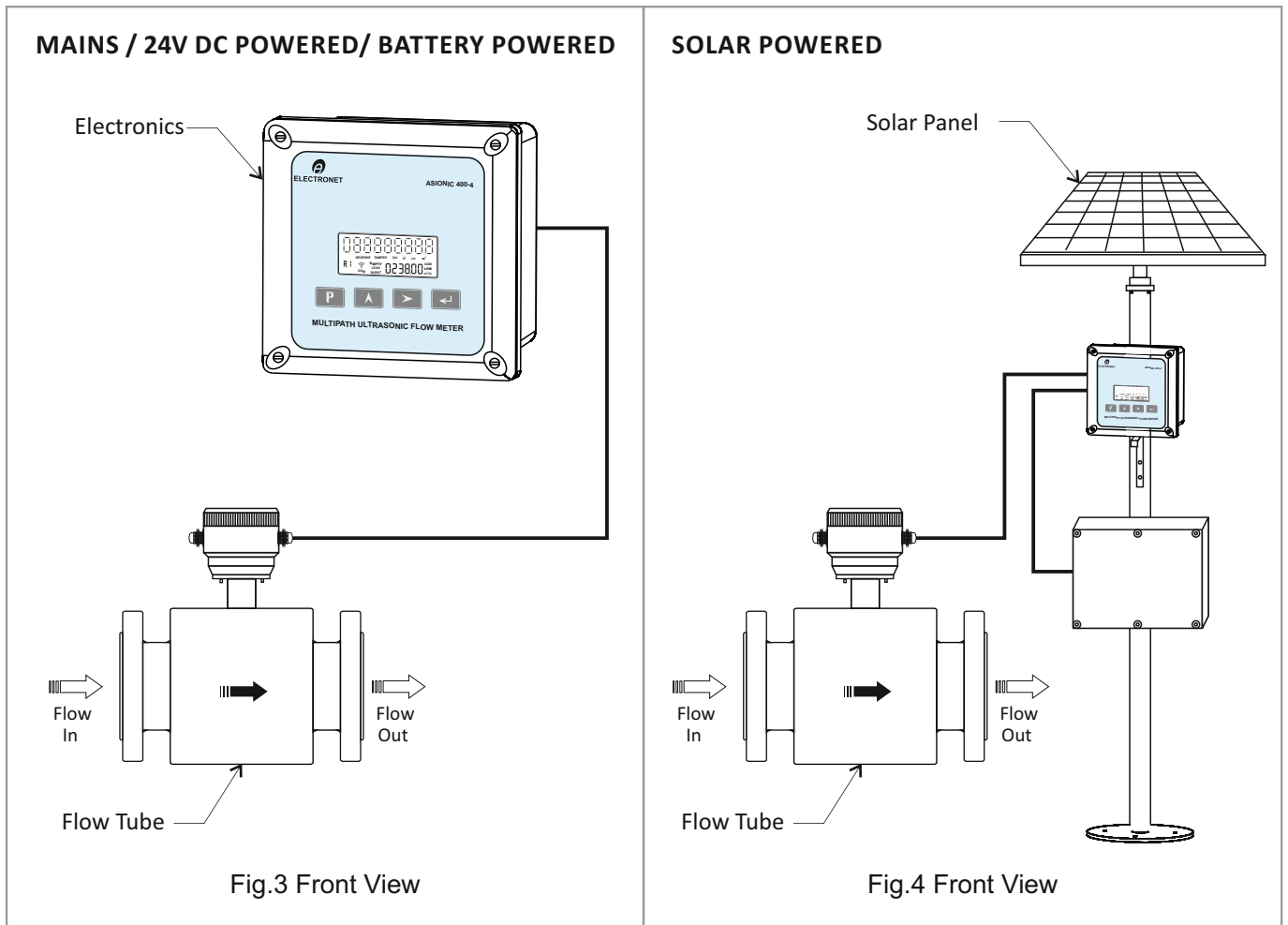

Product Ordering Information :

Order Code for Flow Transmitter			Sample Order Code : TX 3 A1 B1 C1 D2 E1 F1 H2 I2 J2									
Parameter	Code	Description		Parameter	Code	Description						
TX	Electronics Transmitter	TX 1	Field Mount Weather Proof IP67	E	Output 1**	E1	4 to 20 mA					
		TX 3	DIN Standard (IP 54)			EX	NA					
		TX 4	Flameproof (CMRI IIA IIB Certified)	F	Output 2	F1	Pulse (Open Collector Type)					
A	Number Of Paths	A1	Dual			FX	NA					
A2		Three	H	**Communication Output 1 (Any one)	H1	RS485 (MODBUS RTU)						
A3		Four			HX	NA						
B	Power Supply	B1	90 to 250 V AC	I	Communication Output 2 (Any one)	I1	GSM					
		B2	24 V DC			I2	GPRS					
		B3	Battery Operated			IX	NA					
		B5	Solar Powered 24V DC	J	Process Pressure Calibration Range	J1	10 Kg					
		B6	Solar Powered 3.6V DC			J2	20 Kg					
C	MOC Electronics Enclosure	C1	Aluminium Die Cast	JX	NA							
		C2	SS316	Note : ▪ In case of flameproof version only electronics enclosure is flameproof certified. ** Features Available with external power supply not with battery operated.								
D	Electrical Connection	D1	M20 *1.5 F									
		D2	½ Inch NPT F									
		DY	Other									

Order Code for Flow Tube				Sample Order Code : FT 50 L1 M1 N1 O2 P1 Q1 R1 S1 U1 W1									
Parameter	Code	Description	Code	Description	Parameter	Code	Description						
FT	Flow Tube	FT 50	50 NB	FT 250	250 NB	Q	Flange Standard and Rating	Q1	ANSI 150 B16.5				
		FT 65	65 NB	FT 300	300 NB			Q2	ANSI 300 B16.5				
		FT 80	80 NB	FT 350	350 NB			Q3	ANSI 600 B 16.5				
		FT 100	100 NB	FT 400	400 NB			Q4	DIN PN 10 EN 1092-1				
		FT 125	125 NB	FT 450	450 NB			Q5	DIN PN 16 EN 1092-1				
		FT 150	150 NB	FT 500	500 NB			Q6	DIN PN 25 EN 1092-1				
		FT 200	200 NB	FT 600	600 NB			Q7	DIN PN 40 EN 1092-1				
		L	Electronics Location	L1	Integral (Local)			Q8	IS 1538				
L2	Remote			Q9	BS 10 Table D								
M	Remote Cable Length	M1	5 Meter		Q10			BS 10 Table E					
		M2	10 Meter		Q11			BS 10 Table H					
		M3	15 Meter		Q12			AWWA Table D					
		MY	Other		Q13			AWWA Table F					
		MX	NA		QY	Other							
N	Flow Tube Protection Class	N1	IP67		R	Material of construction - Flow Tube	R1	SS304					
		N2	IP68				R2	SS316					
O	Process Connection	O2	Flanged (50 to 600 NB)				R4	MS					
		O5	Socket Weld		S1	SS316							
P	Material of construction - Flange	P1	MS		S	Material of construction - Sensor	S2	PVC					
		P2	CS				SY	Other					
		P3	SS304				U	Inline Flow Sensor	U1	Dual Pair			
		P4	SS316		U2	Three Pair							
W	Inline Pressure Sensor			U3	Four Pair	W	Inline Pressure Sensor	W1	10 Kg				
				W2	20 Kg			WX	NA				
				WX	NA								

Note :
 ▪ Due to our continuous product revisions, design specification and model numbers are subject to change without notice.
 ▪ To be used for industrial applications.
 ▪ Accuracy defined at Lab Conditions.
 ▪ For other requirement please consult factory.

ELECTRONET EQUIPMENTS PVT. LTD.

Factory Address:

Plot No. 8, (SEZ) Phase 1, Kesurdi MIDC, Khandala, Dist.- Satara Pin: 412 801, Maharashtra, India.

Registered Office:

Plot No. 84, 85, 86, Tiny Industrial Estate, Kondhwa Budruk, Pune-411 048, Maharashtra, India.

+91-20-26931476

ho@electronet.co.in

www.eeplindia.com